

# 1800 Series Inverted Bucket Steam Traps

All Stainless Steel for Horizontal Installation

For Pressures to 45 bar...Capacities to 1 090 kg/h

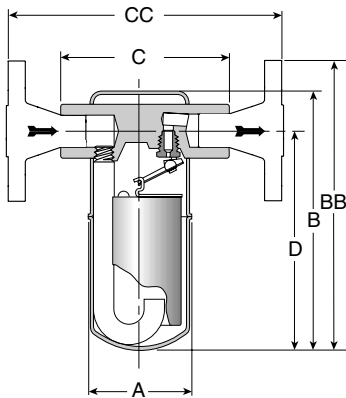

Model 1811 Trap

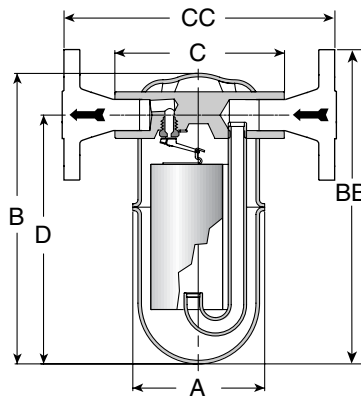

Model 1822 Trap



## Description

A quick and easy "in-line" replacement for other types of side inlet/side outlet traps, the Armstrong 1800 Series brings together all the benefits of energy-efficient inverted bucket operation. Side inlet/outlet all-welded construction means an inverted bucket trap that will operate efficiently on applications such as tracer lines, drips, heating, processing and similar applications.

With the 1800 Series you get freeze-resistant, all-stainless steel construction, with a **three-year guarantee**, plus all the benefits of inverted bucket operation:

- Long, trouble-free service life
- Excellent purging action
- Continuous air venting
- Ease and flexibility of in-line installation

## Maximum Operating Conditions

Maximum allowable pressure (vessel design):

Model 1810, 1811: 28 bar @ 427°C

Model 1822: 45 bar @ 315°C

Maximum operating pressure:

Model 1810: 14 bar

Model 1811: 28 bar

Model 1822: 45 bar @ 316°C

43 bar @ 371°C

41,6 bar @ 427°C

Maximum back pressure: 99% of inlet pressure

## Connections

Screwed BSPT and NPT

Socketweld

Flanged DIN or ANSI (welded)

## Materials

Body:

ASTM A240 Grade 304L

Internals:

All stainless steel – 304

Valve and seat:

Hardened chrome steel – 440F (<38 bar)

Titanium (>38 bar)

## Options

- Insu-Pak™ insulation for Models 1810/1811
- Stainless steel pop drain for Models 1811/1822
- Probe connection
- Wiggle wire

## Specification

Inverted bucket steam trap, type ... in all stainless steel, freeze resistant, without gaskets, with continuous air venting at steam temperature, free-floating stainless steel mechanism, and orifice at the top of the trap. Maximum allowable back pressure 99% of inlet pressure.

## How to Order

Specify:

- Model number
- Size and type of pipe connection
- Maximum working pressure that will be encountered or orifice size
- Any options required

Table ST-106-1. 1800 Series Side Inlet, Side Outlet Trap (dimensions in mm)

Model No.	1810	1811	1822
Pipe Connections	10 – 15 – 20	15 – 20	15 – 20 – 25
"A" Body Outside Diameter	70	70	99
"B" Height	136	167	218
"C" Face-to-Face (screwed & SW)	110	110	127
"CC" Face-to-Face (flanged PN40*)	150	150	190 – 190 – 200
"D" Bottom to $\varnothing$ Inlet	113	138 – 141	186 – 181
Weight in kg (screwed & SW)	0,8	0,9 – 1,0	3
Weight in kg (flanged PN40*)	2,3 – 2,3 – 2,8	2,5 – 3,2	4,5 – 5,2 – 5,6

\* Standard flanges are in carbon steel, stainless steel flanges are optional. Other flange sizes, ratings and face-to-face dimensions are available on request. All models comply with the article 3.3 of the PED (97/23/EC).

**All dimensions and weights are approximate. Use certified print for exact dimensions. Design and materials are subject to change without notice.**

# 1800 Series Inverted Bucket Steam Traps

All Stainless Steel for Horizontal Installation  
For Pressures to 45 bar...Capacities to 1 090 kg/h



Table ST-107-1. Model 1810 Capacity

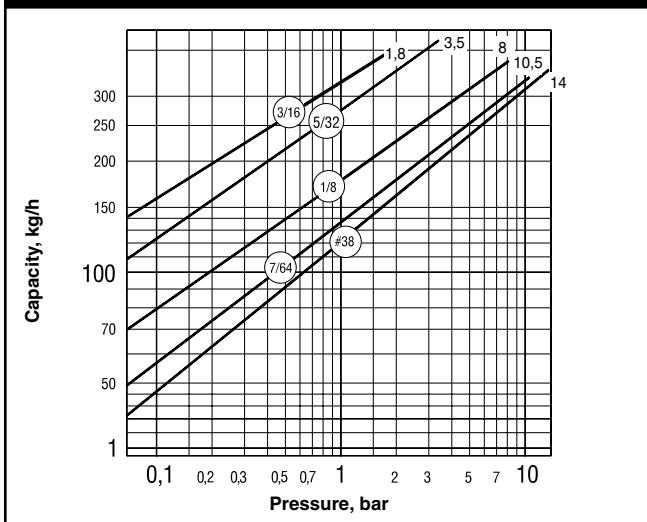
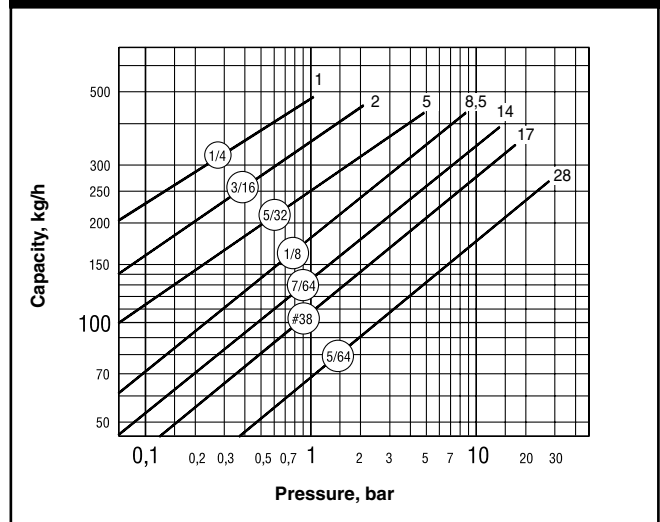

Table ST-107-2. Model 1811 Capacity



## Options

### Pop Drain for Freeze Protection

In general, a properly selected and installed Armstrong trap will not freeze as long as steam is coming to the trap. If the steam supply is shut off, a pop drain should be used to automatically drain the trap. Stainless steel pop drain available for Models 1811 and 1822.

### Maximum Operating Conditions

Pressure: 41 bar  
Temperature: 177°C

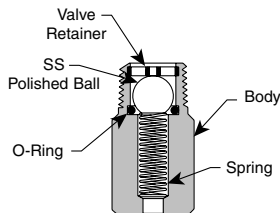

### Insu-Pak™

Now you can insulate the in-line traps in your plant without complicating regular trap maintenance. Insu-Pak, a simple reusable insulation package, cuts the time and cost of in-field installation because it goes on in a snap. And it comes off just as easily. Insu-Pak can prevent trap freeze-up when used with a properly designed condensate manifold. Designed for use with Model 1810 and Model 1811 traps.

**Probe connections** are available for trap monitoring on Models 1811 and 1822.

Table ST-107-3. Model 1822 Capacity

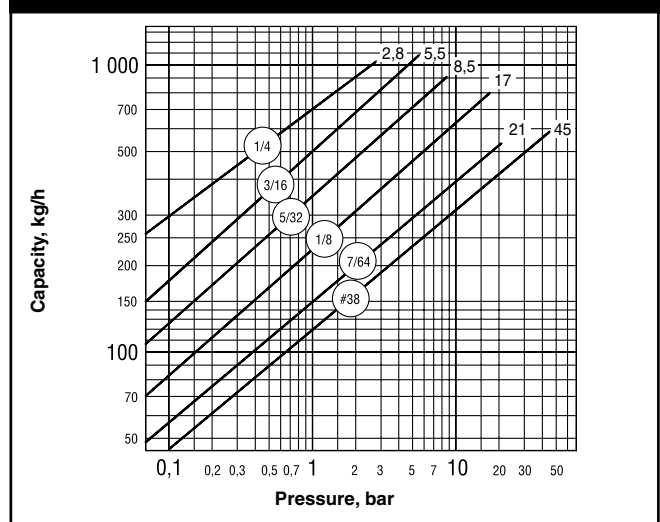

All dimensions and weights are approximate. Use certified print for exact dimensions. Design and materials are subject to change without notice.