

Free Floating Guided Lever Drain Traps

For Loads to 22 300 kg/h...Pressures to 21 bar



Armstrong's cast iron, free-floating guided lever drain traps use the same bodies, caps, lever mechanisms, valves and seats of Armstrong inverted bucket steam traps that have been proven in years of service. Elliptical floats and high leverage make it possible to open large orifices to provide adequate capacity for drain trap size and weight.

The hemispherical valve, seat and leverage of the 1-LD, 2-LD, 3-LD and 6-LD cast iron traps are identical in design, materials and workmanship to those for saturated steam service up to 21 bar with the exception of the addition of a guidepost to assure a positive, leaktight valve closing under all conditions.

Model No.	Valve & Seat	Leverage System	Float	Body & Cap	Gasket
1-LD 2-LD 3-LD 6-LD		Stainless Steel		Cast Iron ASTM A48 Class 30	Compressed Asbestos-free

For information on special materials, consult the Armstrong Application Engineering Department.

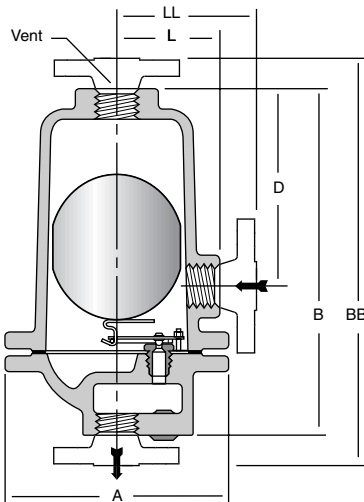

Figure LD-451-1.

Models 2-LD, 3-LD and 6-LD cast iron guided lever drain traps. Model 1-LD has standard top inlet and optional side connection.

Model No.	Cast Iron			
	1-LD	2-LD	3-LD	6-LD
Pipe Connections	15*	15 – 20	15 – 20 – 25	40 – 50
"A"	95	133	162	259
"B"	140	203	273	432
"BB" (PN40**)	N/A	320 – 330	400 – 392	562 – 568
"D"	73	111	155	213
"K" (Ø Outlet to Ø Inlet)	21	–	–	–
"L"	48	62	73	123
"LL" (PN40**)	N/A	179 – 189	142 – 134	180 – 186
Weight in kg (screwed)	1,8	6	10	36
Weight in kg (flanged PN40**)	N/A	8,7 – 9,6	13,6 – 14,2	42,6 – 45,0
Maximum Allowable Pressure (Vessel Design)	21 bar @ 93°C	17 bar @ 232°C		17 bar @ 232°C

Note: Vessel design pressure may exceed float collapse pressure in some cases.

Pipe size of vent connection is same as that of inlet and outlet connections.

* 1/4" outlet.

** Other flange sizes, ratings and face-to-face dimensions are available on request.

† For pressures not exceeding 17 bar, a maximum temperature of 232°C is allowed.

Shade indicates products that are CE Marked according to the PED (97/23/EC). All the other models comply with the Article 3.3 of the same directive.

All dimensions and weights are approximate. Use certified print for exact dimensions. Design and materials are subject to change without notice.