

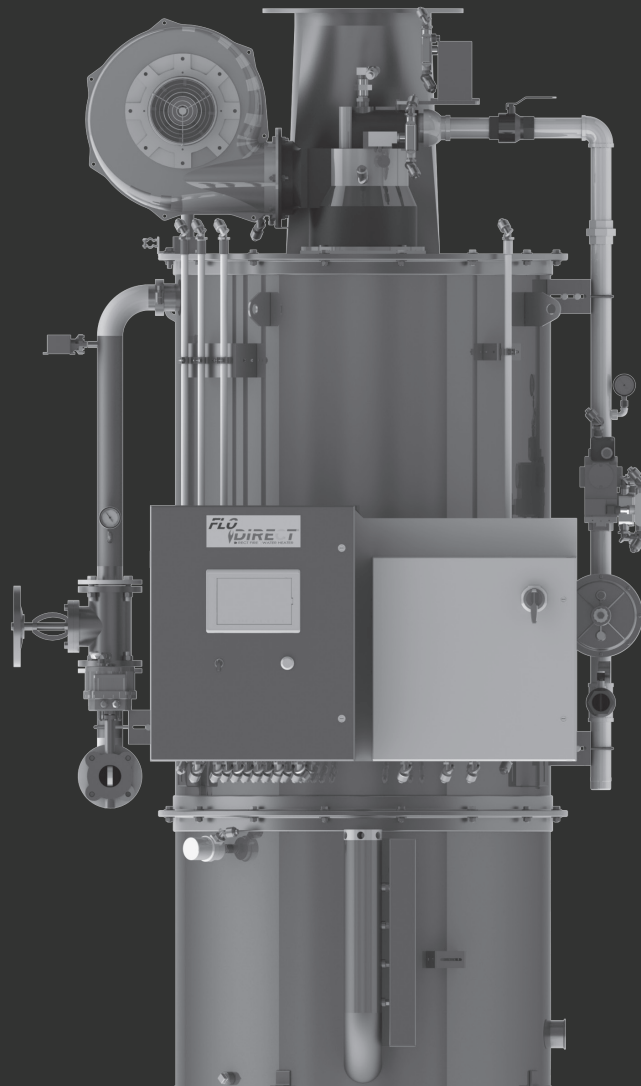

# INDUSTRIAL HOT WATER SOLUTIONS





# Flo-Direct® Complete Thermal Exchange Gas Fired Water Heater

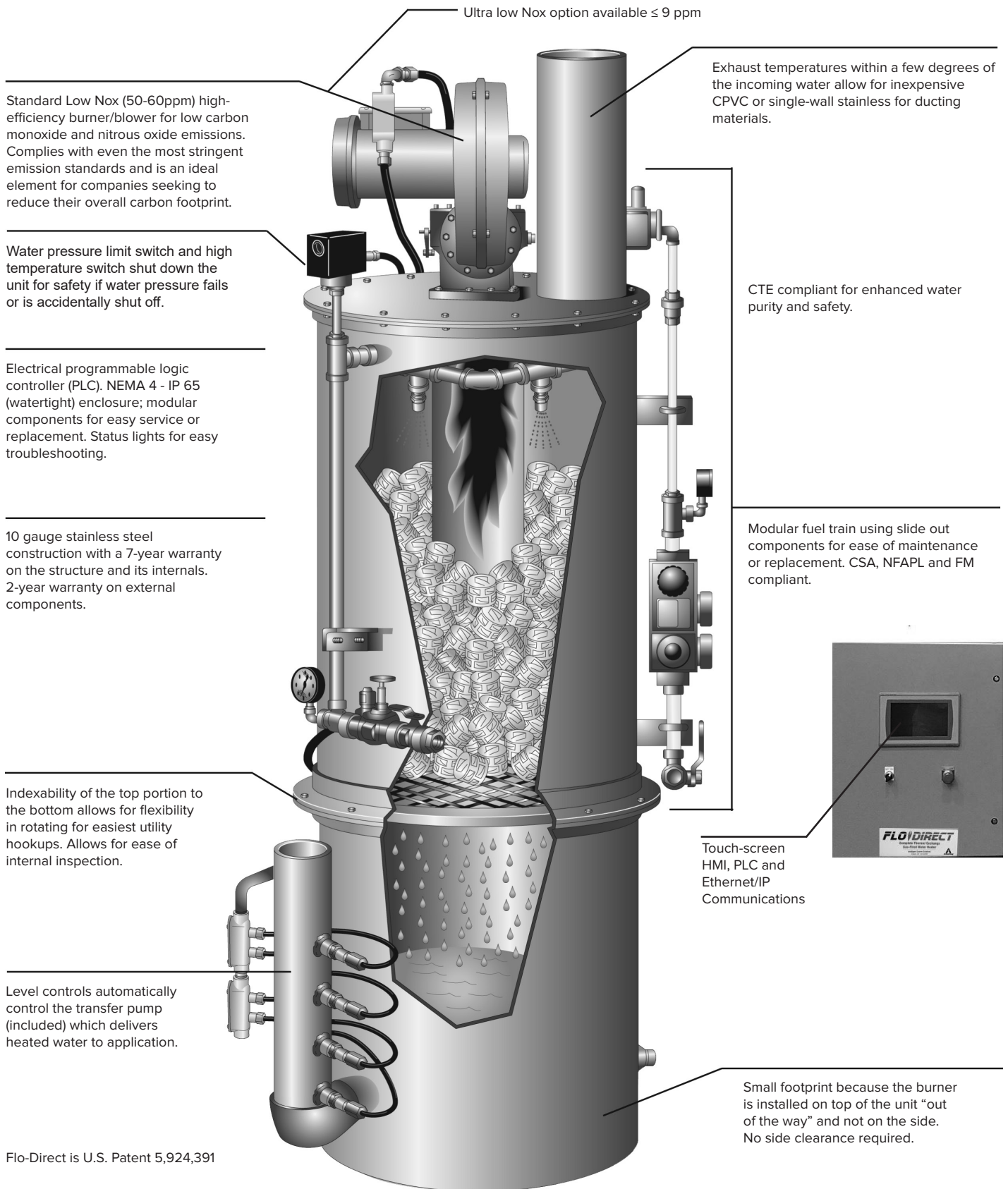

For additional information and to view our educational video, visit: [armstronginternational.com/flo-direct](http://armstronginternational.com/flo-direct)

# Flo-Direct® Complete Thermal Exchange Gas Fired Water Heater



Armstrong Flo-Direct CTE gas fired water heaters offer a complete range of high efficiency, compact, all stainless steel water heaters which are remarkably dependable, simple in design and operation, and suitable for a wide variety of hot water applications.

The Flo-Direct CTE gas fired water heaters often deliver fuel savings as high as 30-60% when compared to steam/water heating systems. Standard operating capacities are between 1 million and 15 million BTU per hour.

With a small footprint, 99.7% or greater high heat value (110% low heat value) heat transfer efficiencies\*, remarkable dependability, ease of maintenance, and the ability to operate well with poor water quality, Armstrong Flo-Direct CTE gas fired water heaters are the product of choice for companies seeking to achieve Energy Conservation Measure (ECM) and Reduced Carbon Footprint objectives.

## Primary Markets include:

### Food Process Industries

- Washdown
- Batch Production
- Vessel Filling
- Tank Cleaning
- Bottle Warming

### Concrete Plants

- Pre-Heated Water for batch production

### Space Heating

- Greenhouses  
Re-Circulated HW for general space heating
- Light Manufacturing/Warehouses  
Re-Circulated HW for general space heating

### General Industry

- Boiler Make-Up Water

Customized Hot Water System Solutions are our specialty. Multiple orientations, configurations and options are available.

The heater may be combined with other equipment such as storage tanks, system pumps, mixing valves and hose stations for a completely integrated and customized hot water system. Extensive customization is available to meet various application and engineering requirements. Full factory testing is performed on all equipment.

Additionally, where appropriate, Armstrong can integrate engineering services, turn key installation, project management, system assessment and optimization along with energy conservation measure (ECM) capability through Armstrong Service Incorporated.

## Flo-Direct Complete Thermal Exchange Gas-Fired Water Heaters deliver unrivaled Performance and Efficiency.

Incoming water is introduced into the top of the water heater through a series of calibrated dispersion nozzles. Cold water travels down through a bed of multifaceted stainless steel packing rings (Pall Rings) which break the water into smaller and smaller droplets.

A burner is mounted on top of the unit, firing downward through a centrally located flame tube. The flame tube is cooled by incoming cold water, and all of the fuel gasses are consumed within this flame tube. The design allows all combustion to take place within a dry and cool environment, and produces very low levels of nitrous oxide (NO) and carbon monoxide (CO).

Heat from the flame enters the lower chamber from the bottom of the flame tube, and travels slowly upward through the packing rings. Efficient heat transfer occurs as the descending water comes in contact with the rising hot gasses as both pass through the bed of packing rings in opposite directions.

This "rain" of hot water then falls into the lower chamber and is pumped out to a storage tank. Water temperatures up to 185°F are available within two minutes after the unit starts.

Outlet water temperature is set with a value controlling the incoming water flow. More incoming water results in cooler outlet water temperatures, and less incoming water produces hotter outlet water temperatures.

The products of combustion are vented out of the top of the unit, and this exhaust is typically within a few degrees of incoming water temperature.

## Features

- CTE Compliant
- Meets multiple global water quality standards (page 4)
- No internal moving parts
- Touch Screen HMI, PLC and Ethernet/IP Communications
- Low-temperature exhaust
- 99.7% or greater high heat value efficiency
- Water treatment not required
- Stainless steel construction
- Takes up minimal floor space
- Seven year warranty on structure/two years on all other components

## Engineered Solutions

Armstrong can provide integrated engineering, turnkey installation and project management services. Additionally, Armstrong can perform system assessments and optimizations and identify Energy Conservation Measures (ECMs).



# Flo-Direct® Complete Thermal Exchange Gas Fired Water Heater

## CTE Technology

Developed from direct contact water heating science which was first introduced more than two decades ago, Complete Thermal Exchange (CTE) technology has revolutionized high efficiency water heating methods. Today CTE enjoys a proven record and has rapidly become the new standard in high efficiency water heating and energy savings.

While traditional direct contact water heating can offer significant energy savings when compared to a conventional steam boiler system, the Armstrong Flo-Direct CTE gas fired water heater offers an unparalleled, 99.7% high heat value (110% approx. low heat value) efficiency rating\* throughout each phase of its operation cycle.

The sustained operational efficiency of Flo-Direct CTE gas fired water heaters creates the most energy efficient method of hot water production currently available.

## No Scale Build-Up

The Flo-Direct CTE gas fired water heater's unique design prevents scale build-up because there are no "hot spots" internally or externally, and because calcium is prevented from completely falling out of suspension during operation. As a result, the mineral content of the influent water and the effluent water will be equal.

## Armstrong Flo-Direct CTE gas fired water heaters achieve CTE Standards

The Flo-Direct CTE direct contact water heaters, meet five standards not available with the older designs and traditional methods of direct contact water heater technology:

1. CTE units maintain a minimum of 99.7% high heat value (110% approx. low heat value) efficiency in all modes of operation, not just under optimal conditions.
2. CTE units have multiple thermal passes. Water and the combustion gasses (or heat from the combustion) repeatedly come in contact. This ensures that the maximum amount of heat or energy from combustion is transferred to the water.
3. CTE units have a dry combustion chamber. This is vital to maintaining complete combustion at all times during operation.
4. CTE units maintain complete combustion at all times.
5. CTE units must have an integral water quality integrity system. Operational procedures must be in place to ensure that effluent water quality is equal to the influent water quality.

## Complete Combustion = Complete Water Quality

While many traditional-method direct contact water heaters spray water directly on the flame – sometimes called "flame quenching" – Flo-Direct, using CTE technology, avoids this process altogether. According to the Industrial Heating Equipment Association's "Combustion Technology Manual," flame quenching promotes incomplete combustion, and produces alcohols, aldehyde, formic acid, higher order acids, carbon monoxide, as well as carbon dioxide and water vapor. With CTE technology, Flo-Direct maintains 99.7% high heat value\* (110% approx. low heat value) combustion efficiency, while maintaining water quality at all times.

\*See page 10 for high heat value (HHV) and low heat value (LHV) explanation.

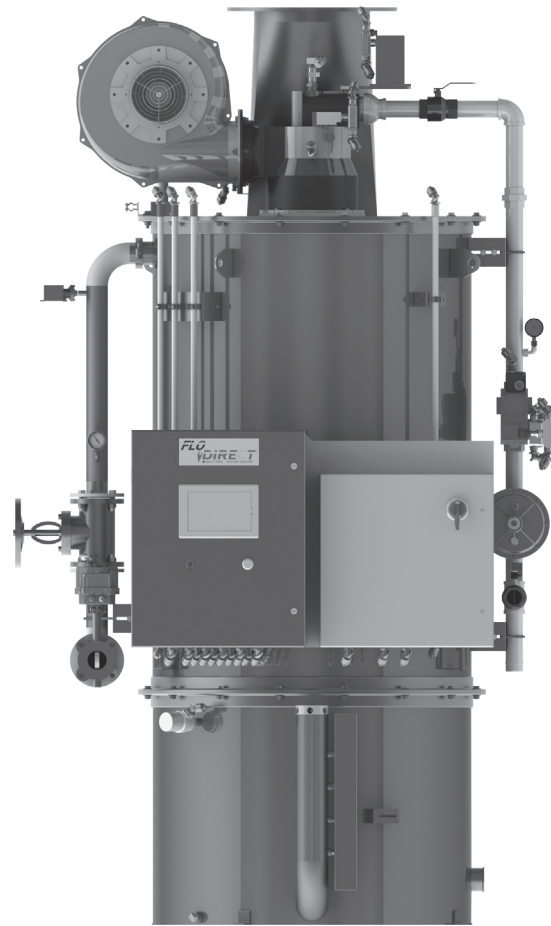

## Global Water Quality Standards

Flo-Direct Complete Thermal Exchange (CTE) Gas Fired Water Heating Technology significantly limits the effluent water chemical additives typically attributed to other process water heating systems.

Our unique CTE water heating process deaerates the water significantly. Independent third party testing has verified CTE technology can actually remove some chemical constituents from the influent water.

NSF test results show that the effluent water from a Flo-Direct CTE Gas Fired Water Heater meets US, European Union and PRC bottled drinking water standards\* and has been tested and documented as fully compliant with:

- USFDA - The United States Food and Drug Administration, Code of Federal Regulations Bottled Water Standard: Chapter I, Title 21, Part 165, Subpart B, Section 165.110.
- EU-TRW - The European Union Directives(s) - Treated Waters: 98/83/EC.

\* Peoples Republic of China Standards for Drinking Water: GB5749-2006

\*Statement presumes influent water also meets listed standards.

# Flo-Direct® Complete Thermal Exchange Gas Fired Water Heater



Specifications	
Gas Supply Pressure	2 - 6 psig / .14 - .41 bar
Dynamic Water Supply Pressure	Constant water pressure (+/-5 psi variation maximum) within a minimum of 30 psig/2 bar and a maximum of 100 psig/6.8 bar range is required for optimum performance.
Maximum Inlet Water Temperature	120°F (49°C)
Minimum Inlet Water Temperature	32°F (0°C)
Maximum Effective Outlet Temperature	185°F (85°C)

Materials	
Upper and Lower Canister	Type 304 Stainless Steel #10 Glass Finish
Inlet Gas Train Piping	Malleable Iron with Standard Yellow Finish
Inlet Water Train Piping	Copper with Brass/Bronze Fittings
Spray Ring	Type 304/316 Stainless Steel
Canister Gaskets	Warco White
Flame Tube	Type 304 Stainless Steel
Pall Rings	Type 304 Stainless Steel

Optional/Custom materials of construction available upon request.

### Standard Sizing Formulas

$$\frac{\text{gpm} \times \Delta T}{2} = \text{AFD Model}$$

$$\frac{(\text{AFD Model}) \times 2}{\Delta T} = \text{gpm}$$

$$(\text{AFD Model}) \times 2 = \Delta T \text{ gpm}$$

Use the Flo-Direct sizing tool at [armstronginternational.com/flo-direct](http://armstronginternational.com/flo-direct)

### Standard Formula Key

gpm = Gallons per Minute

$\Delta T$  = Temperature rise (°F)

AFD = Armstrong Flo-Direct (e.g., 1000, 5000)

### Metric Sizing Formulas

$$\frac{\text{lpm} \times \Delta T}{4.2} = \text{AFD Model}$$

$$\frac{(\text{AFD Model}) \times 4.2}{\Delta T} = \text{lpm}$$

$$(\text{AFD Model}) \times 4.2 = \Delta T \text{ lpm}$$

Use the Flo-Direct sizing tool at [armstronginternational.eu/flo-direct](http://armstronginternational.eu/flo-direct)

### Metric Formula Key

lpm = Liters per Minute

$\Delta T$  = Temperature rise (°C)

AFD = Armstrong Flo-Direct (e.g., 1000, 5000)

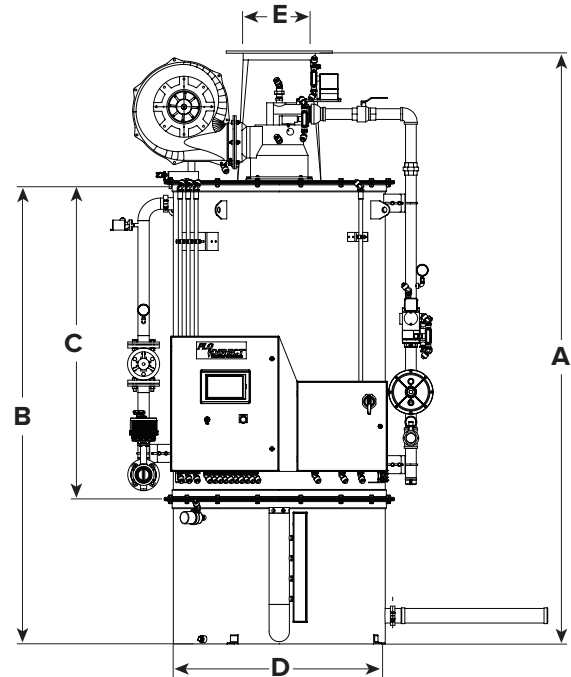

### Flo-Direct Dimensions and Weights

Model	Connections				Dimensions										Weight		btu/hr
	1		2		A		B		C		D		E		lb	kg	
	in	mm	in	mm	in	mm	in	mm	in	mm	in	mm	in	mm			
1000	1	25	1	25	95	2413	71	1803	39	991	24	610	8	203	825	375	1,000,000
1500	1	25	1	25	97	2464	73	1854	41	1041	26	660	8	203	850	386	1,500,000
2000	1-1/2	40	1-1/2	40	100	2540	76	1930	44	1118	30	762	10-3/4	273	1500	680	2,000,000
3000	2	50	1-1/2	40	100	2540	76	1930	44	1118	36	914	12	305	1600	725	3,000,000
5000	2-1/2	65	2	50	127	3226	97	2464	65	1651	44	1118	16	406	2500	1136	5,000,000
6000	3	80	2	50	132	3353	100	2540	70	1778	47	1194	18	457	2900	1316	6,000,000
7000	3	80	2	50	139	3531	107	2718	77	1956	50	1270	18	457	3200	1455	7,000,000
9000	3	80	2	50	169	4293	139	3531	107	2718	60	1524	20	508	5000	2273	9,000,000
10000	3	80	2	50	181	4597	151	3835	119	3023	61	1549	20	508	5200	2405	10,000,000
12000	4	100	3	80	181	4597	151	3835	119	3023	61	1549	22	559	5500	2495	12,000,000
15000	4	100	3	80	192	4877	161	4089	129	3277	70	1778	24	610	7000	3175	15,000,000

All dimensions and weights are approximate. Use certified print for exact dimensions. Design and materials are subject to change without notice.

Flo-Direct Complete Thermal Exchange Gas Fired Water Heaters deliver a wide variety of hot water solutions.

## Non-Recirculating Hot Water Systems

Non-recirculating hot water systems are suitable for installations which experience frequent demand or processes which can accommodate the evacuation of a dead-leg before receiving heater set point water temperatures.

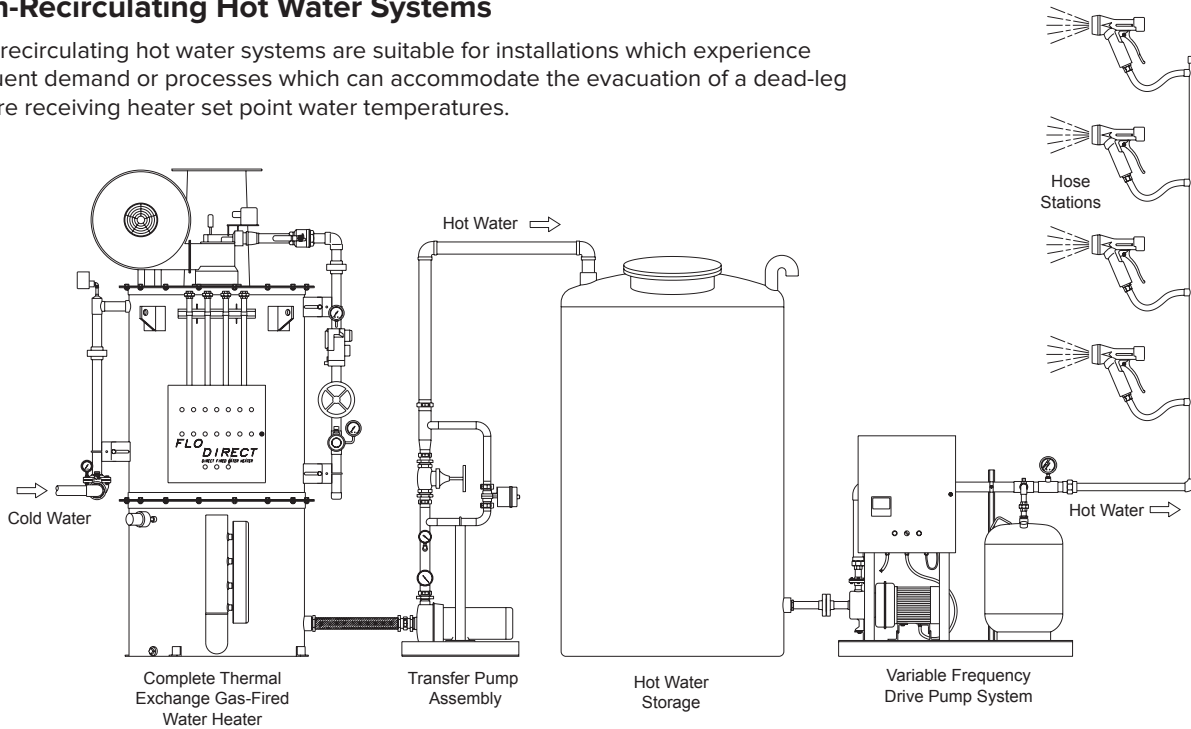

## Recirculating Hot Water Systems

Recirculating hot water systems are suitable for installations which experience diverse draw-off or processes which cannot accommodate the evacuation of a dead-leg before receiving heater set point water temperatures.

Note: Recirculating hot water systems which idle at zero demand for long periods or experience a radiant heat loss during recirculation may require an immersion type heater in the storage tank.

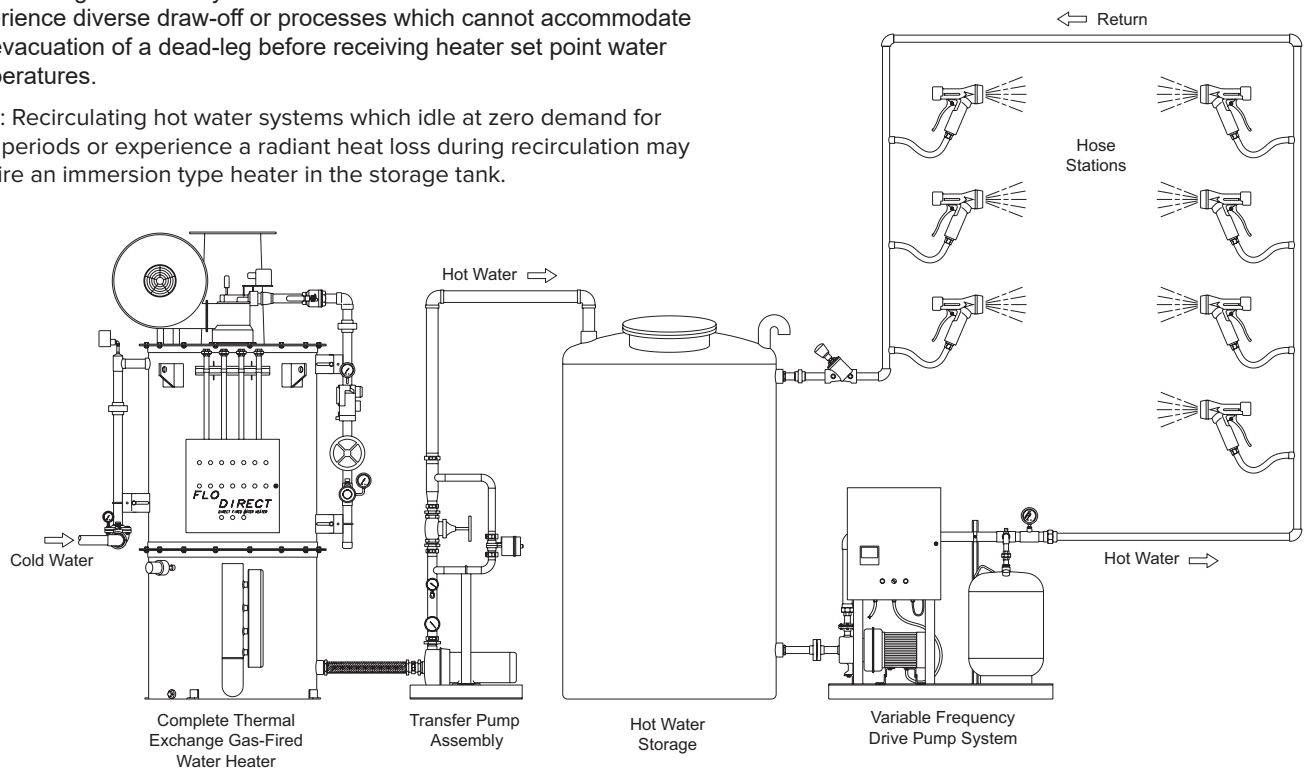

# Hot Water Systems

## Multiple Temperature Hot Water Systems

Multiple temperature hot water systems can be designed as either recirculating, non-recirculating or a combination of both. To achieve multiple temperatures for the same hot water system, Armstrong recommends one or more Emech™ electronic water temperature controllers along with Armstrong thermostatic hot and cold water hose stations.

Emech™ Water Temperature Controller

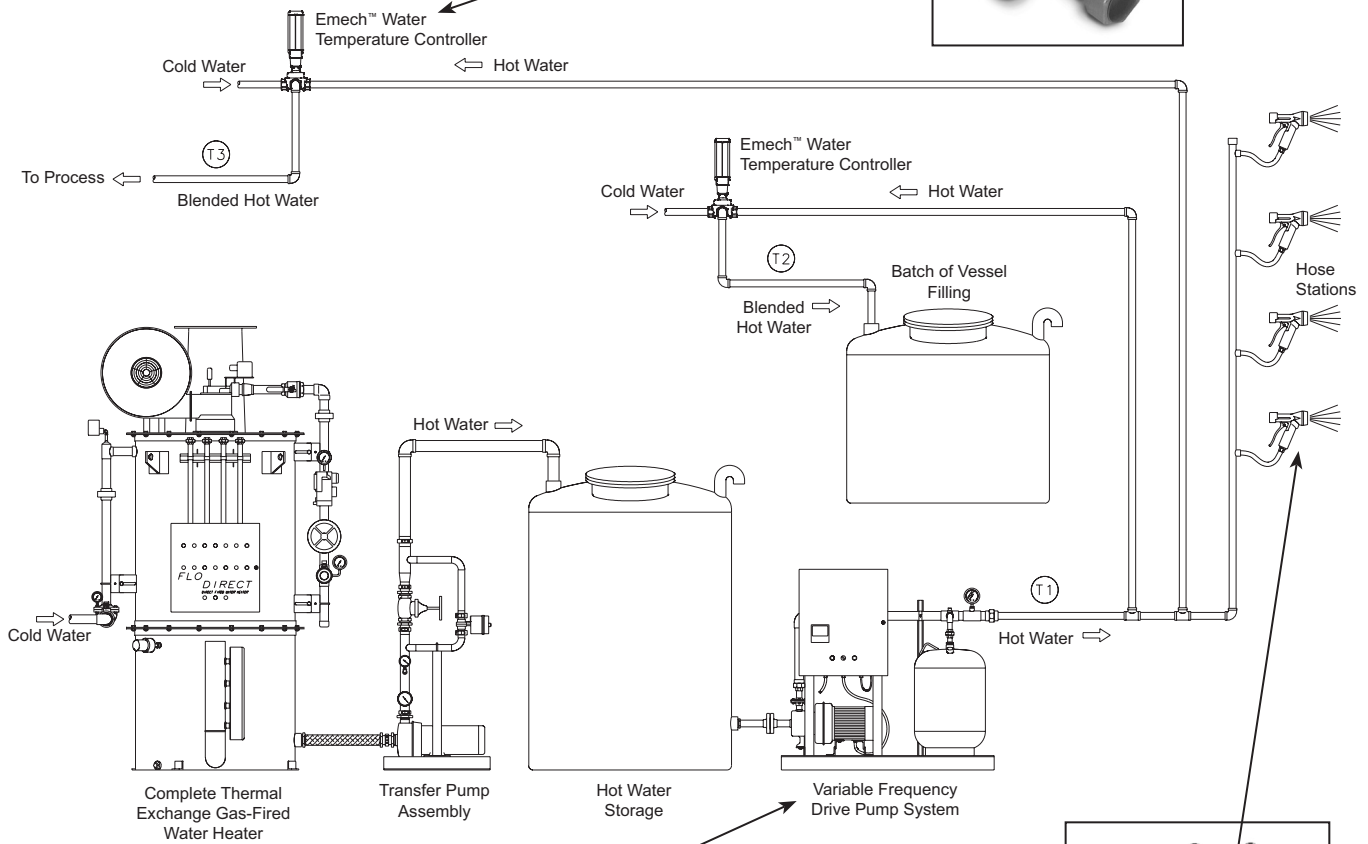

Armstrong Variable Frequency Drive Pump Assemblies

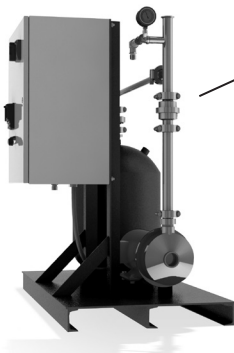

It is strongly recommended that the hot water storage temperatures are maintained at 140°F (60°C) or higher in accordance with US OSHA and CDC and corresponding global Legionella guidelines. If water temperatures below 140°F (60°C) are required, Armstrong offers a variety of supplemental thermostatic, electronic and digital water temperature controllers.

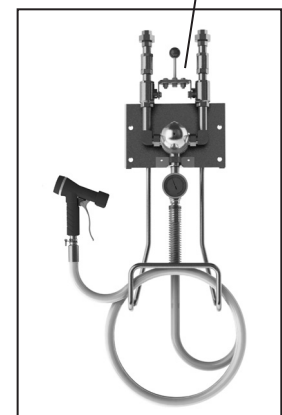

Armstrong Hot/Cold Water Hose Station

## Variable Frequency Drive Pump Assemblies

The Armstrong Variable Frequency Drive (VFD) Pump Packages team with our Flo-Direct CTE Water Heaters and our optional storage tanks at a central location to maintain flow and pressure levels at variable usage draw-off points within the hot water distribution system.

Standard and custom designed assemblies are application engineered and configured specifically to the needs of the installation site to provide a complete high efficiency low energy consumption hot water solution.



## Precision Mixed Water Flow & Temperature Control

---

### Emech™ Water Temperature Mixing Unit

Emech 3-port mixing valves utilize ceramic shear action disc technology to provide tight shut-off, high pressure differential capability, and a long service life.

Fitted with an electronic actuator and integral temperature sensor, Emech delivers high-performance stand-alone temperature control with  $\pm 1^\circ\text{F}$  ( $\pm 0.5^\circ\text{C}$ ) accuracy over a  $32^\circ\text{F}$  to  $212^\circ\text{F}$  ( $0^\circ\text{C}$  to  $100^\circ\text{C}$ ) setpoint range.

#### Emech Water Temperature Mixing Units offer:

- Five Models
- On-board keypad for valve operation
- Flow capacities up to 1000GPM/3800LPM
- Operating inlet temperature range:  $-13^\circ\text{F}$  to  $257^\circ\text{F}$  ( $-25^\circ\text{C}$  to  $125^\circ\text{C}$ ).
- Analog (4-20mA) input and output control signals.
- Software configurable control settings
- 316 Stainless Steel construction





# Steamix® - Will Not Pass Live Steam



**Whisper quite** operation is achieved by special steam diffuser design.

**Rugged** steam valve seat is made from new high-temperature-resistant polymer.

**Will not pass live steam** if cold water pressure falls or fails completely.

**Fails safe.** Steamix will deliver only cold water if the primary operating component (diaphragm) is damaged.

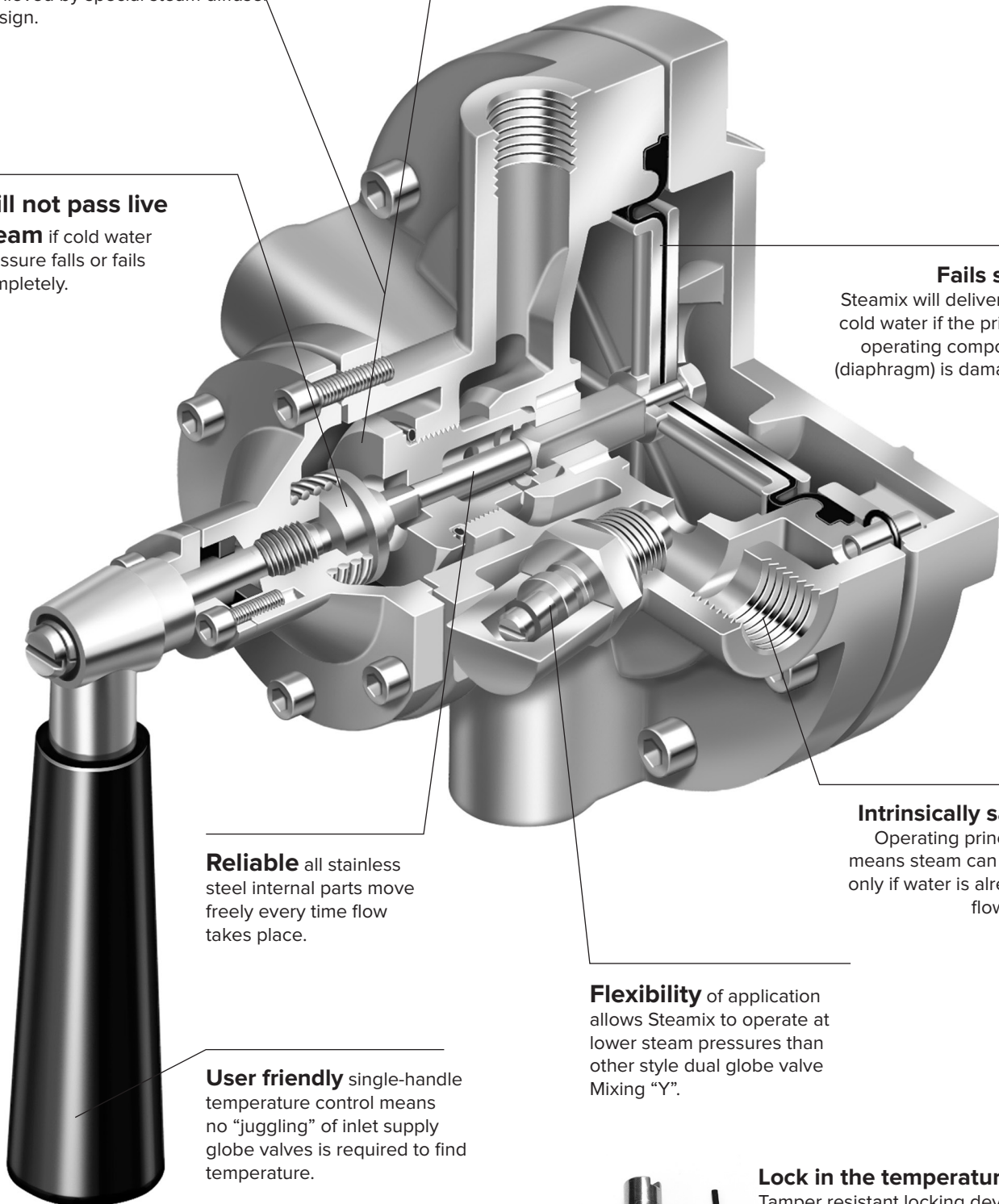

**Reliable** all stainless steel internal parts move freely every time flow takes place.

**Intrinsically safe.** Operating principle means steam can flow only if water is already flowing.

**User friendly** single-handle temperature control means no "juggling" of inlet supply globe valves is required to find temperature.

**Flexibility** of application allows Steamix to operate at lower steam pressures than other style dual globe valve Mixing "Y".

**Lock in the temperature.** Tamper resistant locking device option allows Steamix to be preset to a desired temperature and locked. Discourages adjustments by unauthorized personnel.



1-year warranty on mixing unit wetted components.



## Steamix® - Steam & Water Hose Stations – Standard

### Steamix - Standard

The Steamix – Standard series is supplied fully assembled and pressure tested in the following configurations.

**Steamix Model 2030** - is a steam/water mixing valve of brass/stainless steel construction.

**Steamix Model 2031** - is a steam/water mixing valve of brass/stainless steel construction. The valve is supplied as standard with 3/4" inlet union connections with integral strainers, an outlet ball valve for flow control and an outlet dial thermometer.

**Steamix Model 2032** - is a steam/water mixing valve of brass/stainless steel construction. The valve is supplied as standard with 3/4" inlet union connections with integral strainers, an outlet ball valve for flow control and an outlet dial thermometer. The unit is supplied installed on a stainless steel hose rack.

**Steamix Model 2033 (shown)** - is supplied as above and also includes 25 feet of "safety yellow" washdown hose, a rubber cushioned spray nozzle with, swivel adapter and a stainless steel nozzle hook.



**Steamix Model 2033-25**

## Steamix - Premium

The Steamix – Premium series is supplied fully assembled and pressure tested in the following configurations.

**Steamix Model 2031P** - is a steam/water mixing valve of brass/stainless steel construction. The valve is supplied as standard with integral inlet supply risers comprising 3/4" Y-type strainers and 3/4" ball valves cross-linked by a stainless steel bridge piece and lever for simultaneous on/off control of both inlet supplies. The unit is supplied with stainless steel dual scale top mount Thermometer and Inlet Check Valves.

**Steamix Model 2032P** - is a steam/water mixing valve of brass/stainless steel construction. The valve is supplied as standard with integral inlet supply risers comprising 3/4" Y-type strainers and 3/4" ball valves cross-linked by a stainless steel bridge piece and lever for simultaneous on/off control of both inlet supplies. The unit is supplied with a stainless steel hose rack. Stainless Steel dual scale top mount Thermometer and Inlet Check Valves.

**Steamix Model 2033P (shown)** - is a steam/water mixing valve of brass/stainless steel construction. The valve is supplied as standard with integral inlet supply risers comprising 3/4" Y-type strainers and 3/4" ball valves cross-linked by a stainless steel bridge piece and lever for simultaneous on/off control of both inlet supplies. The unit is supplied with a stainless steel hose rack. Stainless Steel dual scale top mount Thermometer and Inlet Check Valves.

Steamix Model 2033P also includes 25 feet of "safety yellow" washdown hose rated, low-heat-transfer polymer spray nozzle with trigger guard, swivel adapter and a stainless steel nozzle hook.

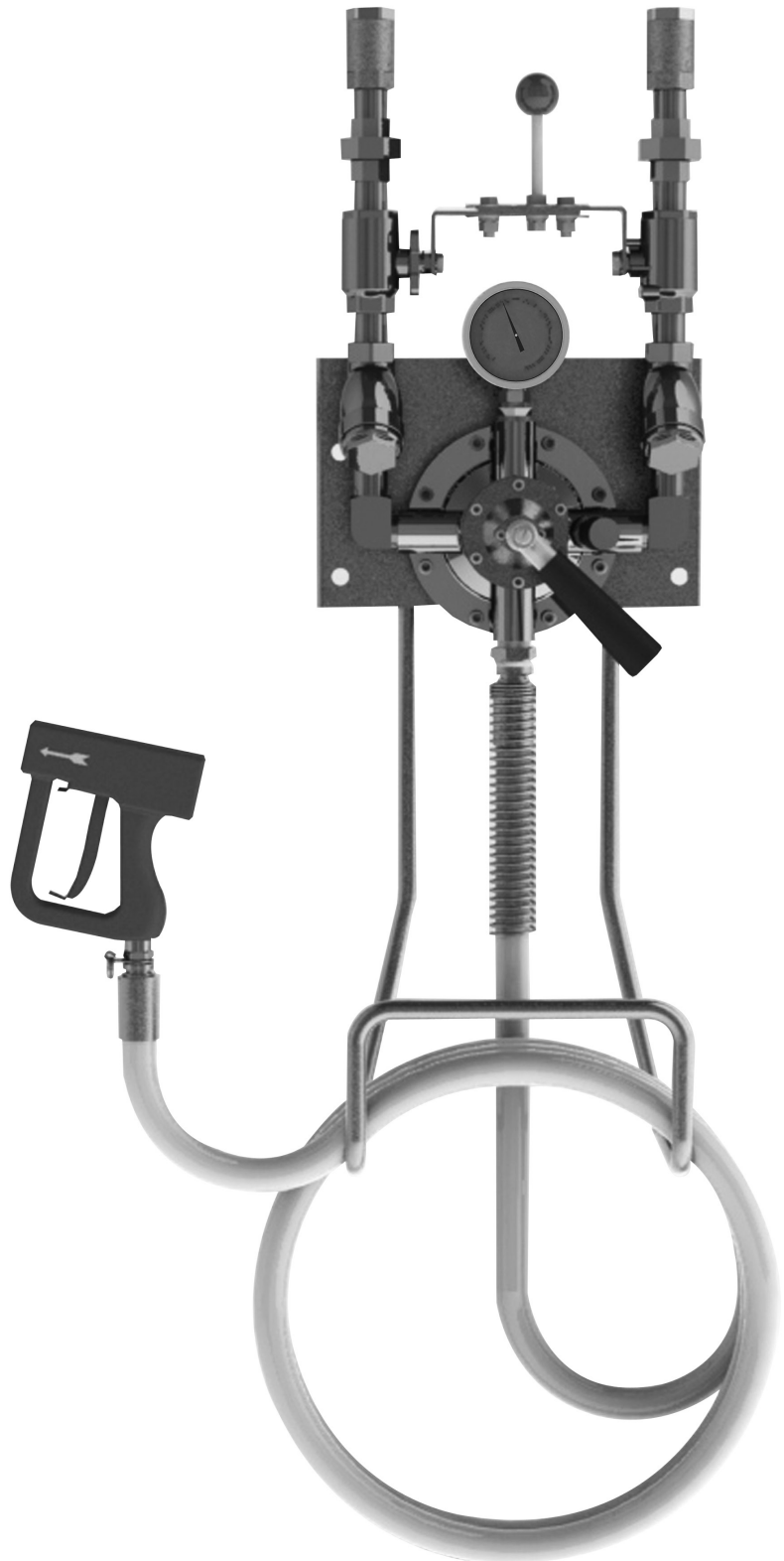

Steamix Model 2033P-25

### Steamix - Stainless Steel

The Steamix – Stainless Steel series is supplied fully assembled and pressure tested in the following configurations.

**Steamix Model 2030SS** - is a steam/water mixing valve of Type 304 stainless steel construction.

**Steamix Model 2031SS** - is a steam/water mixing valve of Type 304 stainless steel construction. The valve is supplied as standard with all stainless steel (SS) integral inlet supply risers comprising 3/4" Y-type strainers and 3/4" ball valves cross-linked by a stainless steel bridge piece and lever for simultaneous on/off control of both inlet supplies. Stainless Steel dual scale top mount Thermometer and Stainless Steel Inlet Check Valves.

**Steamix Model 2032SS** - is a steam/water mixing valve of Type 304 stainless steel construction. The valve is supplied as standard with all stainless steel (SS) integral inlet supply risers comprising 3/4" Y-type strainers and 3/4" ball valves cross-linked by a stainless steel bridge piece and lever for simultaneous on/off control of both inlet supplies. The unit is supplied with a stainless steel hose rack. Stainless Steel dual scale top mount Thermometer and Stainless Steel Inlet Check Valves.

**Steamix Model 2033SS (shown)** - is a steam/water mixing valve of Type 304 stainless steel construction. The valve is supplied as standard with all stainless steel (SS) integral inlet supply risers comprising 3/4" Y-type strainers and 3/4" ball valves cross-linked by a stainless steel bridge piece and lever for simultaneous on/off control of both inlet supplies. The unit is supplied with a stainless steel hose rack. Stainless Steel dual scale top mount Thermometer and Stainless Steel inlet Check Valves.

The STEAMIX Model 2033SS also includes 25 feet of "safety yellow" washdown hose, SS rubber cushioned spray nozzle with SS swivel adapter and a stainless steel nozzle hook.

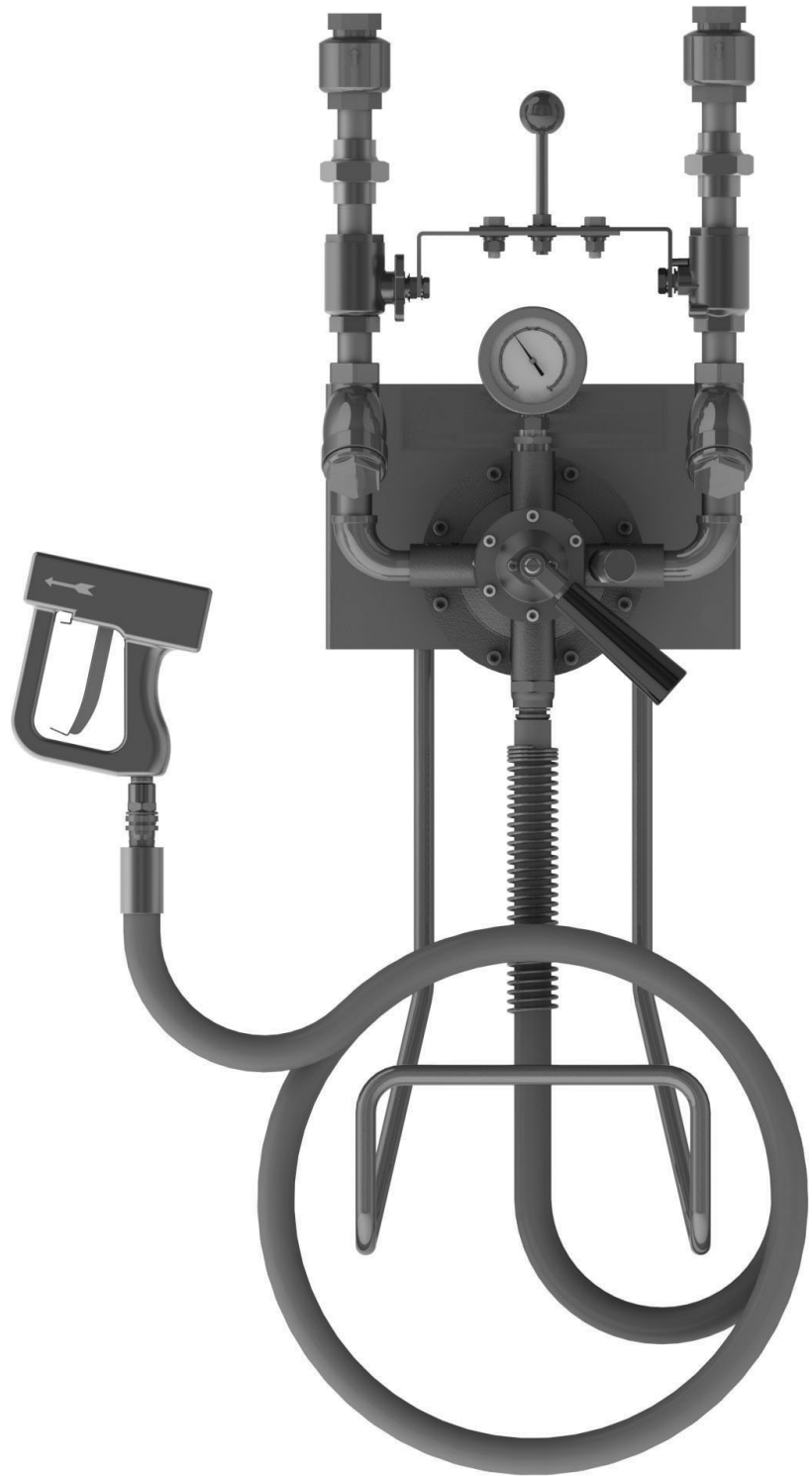

**Steamix Model 2033SS-25**

## Armstrong - Hot & Cold Water Hose Stations

### Armstrong - Hot & Cold Water Hose Stations

Armstrong Hot and Cold water hose stations replace the basic Mixing Y with a Rada® 320 thermostatic mixing valve as the primary water temperature controller.

With the Rada 320 you can:

- Change outlet water temperature from full cold to the field-adjustable maximum limit stop in a single handle turn
- Set and lock to a single temperature and maintain outlet temperatures +/-2°F (1°C) in the event of inlet pressure and/or temperature fluctuation or change
- Protect the operator with a thermal-shutdown feature if the cold water inlet supply fails

**IMPORTANT NOTE:** Thermostatic products used by our competitors for this application cannot provide a temperature range from full cold to the field-adjustable maximum limit stop. Nor can they access temperatures within 5°F (2°C) of either inlet supply temperature.

#### Model 3031 – Standard

Rada 320 Thermostatic Mixing Valve with integral risers for simultaneous on/off control of both inlet supplies. The unit is supplied fully assembled and pressure tested installed on a stainless steel wall mounting plate.

#### Model 3032 – Standard

Rada 320 Thermostatic Mixing Valve with integral risers for simultaneous on/off control of both inlet supplies. The unit is supplied fully assembled and pressure tested installed on a stainless steel hose rack.

#### Model 3033 – Standard

Rada 320 Thermostatic Mixing Valve with integral risers for simultaneous on/off control of both inlet supplies. The unit is supplied fully assembled and pressure tested installed on a stainless steel hose rack.

Model 3033 is supplied with 25' Armstrong "safety yellow" washdown hose, SS rubber cushioned spray nozzle with swivel adaptor and stainless steel nozzle hook.

#### Armstrong – Hot & Cold Water Hose Stations - Premium

The Armstrong Hot & Cold Hose Stations – Premium series are supplied as above with inlet check valves and a corrosion resistant industrial nickel plating on all components excepting Rada 320 (heavy duty industrial chrome).

Models Available:

3031S, 3032S & 3033S

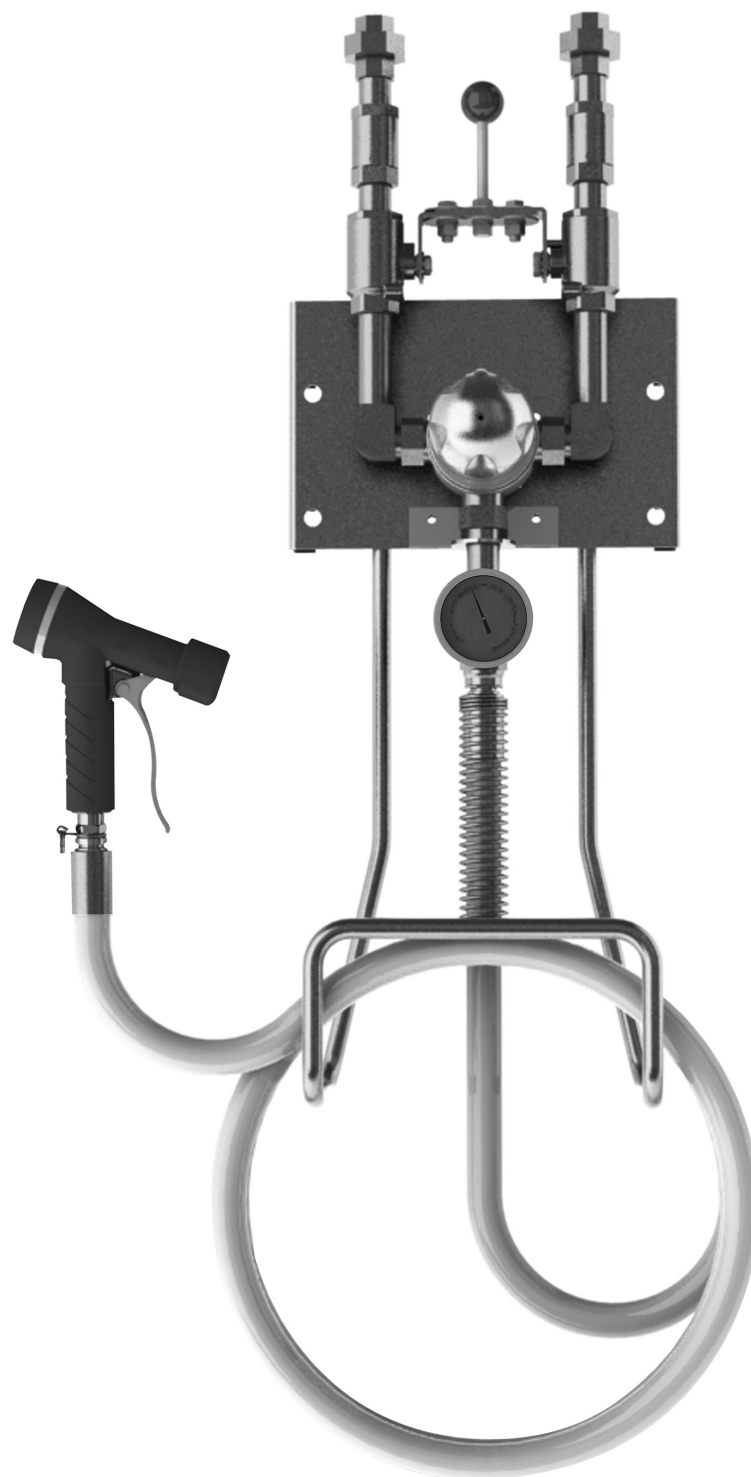

**Model 3033-25**



## Armstrong - Single Temperature Hose Stations

### Armstrong Single Temperature Hose Stations

Armstrong Single Temperature Hose Stations are supplied in type 316 Stainless Steel and are ideal for heavy duty wash down in systems which do not require temperature adjustment at the point of use.

**Model 1032** - 316 Stainless Steel full port 3/4" NPT) ball valve affixed to a 316 Heavy-duty stainless steel hose rack with mounting plate, stainless steel hose strain relief and stainless steel tee outlet thermometer. The unit is supplied fully assembled and pressure tested.

**Model 1033** - As above with 25' Armstrong "safety yellow" washdown hose, SS rubber cushioned spray nozzle with swivel adaptor and stainless steel nozzle hook. The unit is supplied fully assembled and pressure tested.

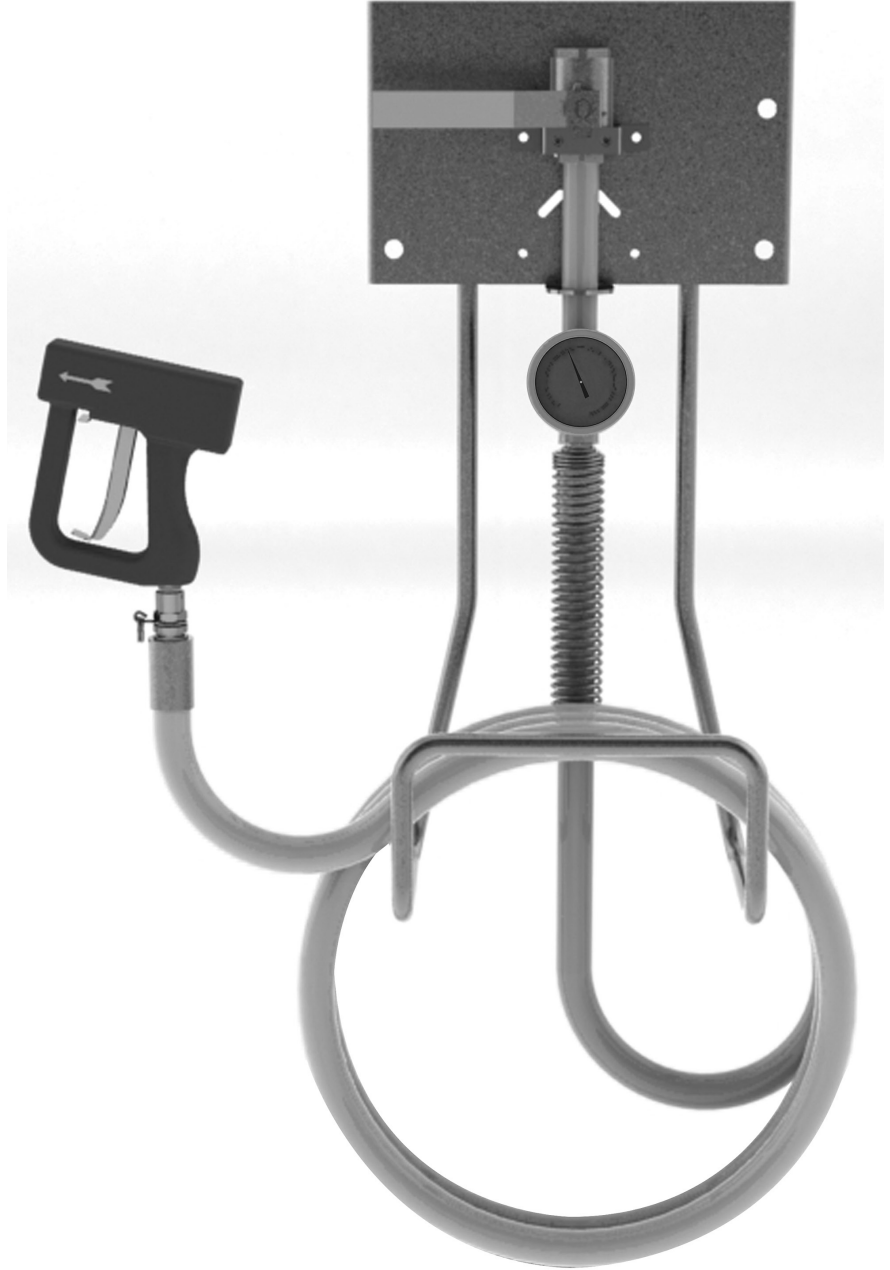

Model 1033-25





INTELLIGENT SOLUTIONS IN STEAM, AIR, AND HOT WATER

**Armstrong International**

North America • Latin America • India • Europe / Middle East / Africa • China • Pacific Rim

[armstronginternational.com](http://armstronginternational.com)